

# BABY COT ASSEMBLY INSTRUCTION

## СБОРКА ДЕТСКОЙ КРОВАТИ

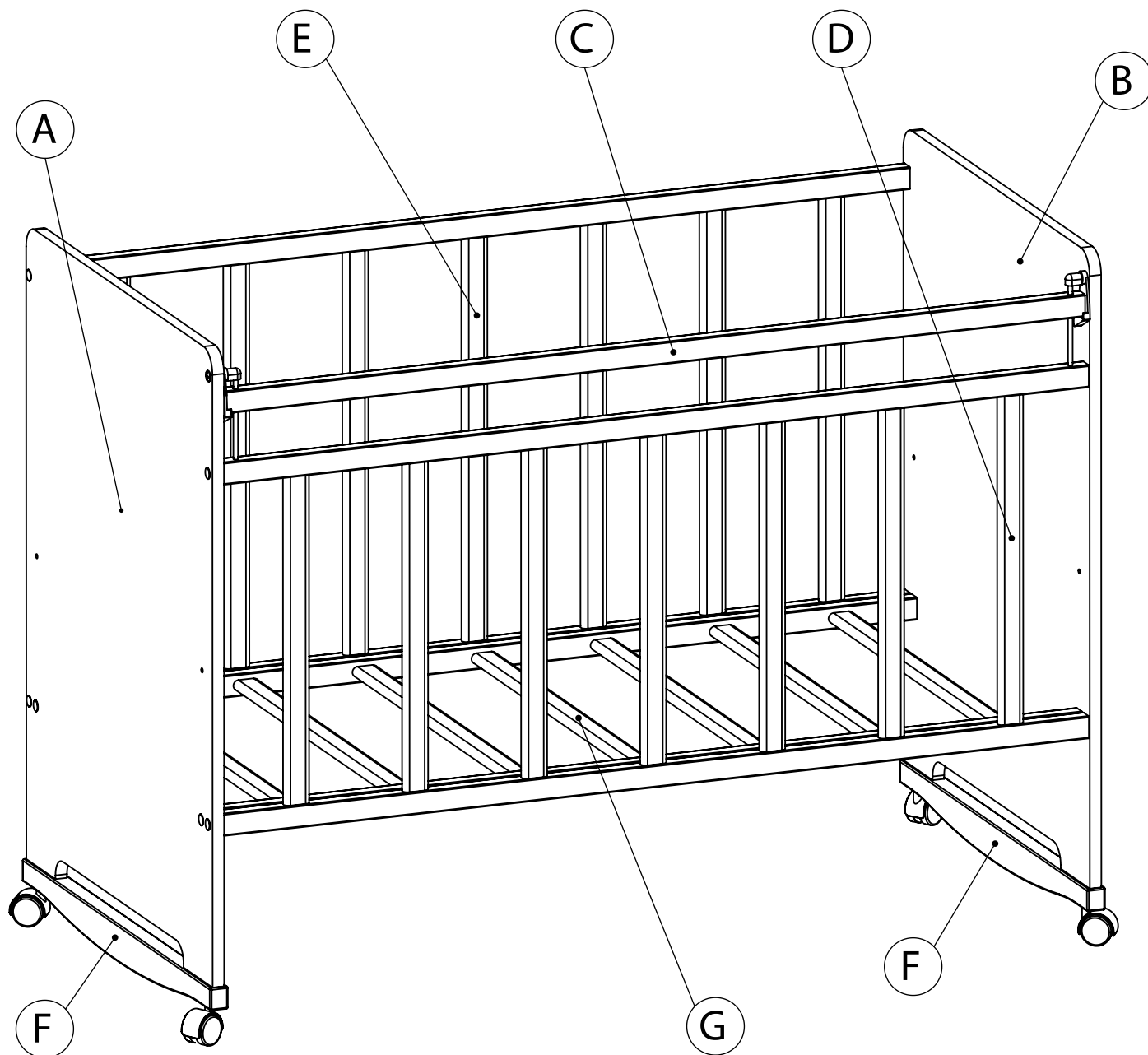

**Indigo**

**EN-** IMPORTANT: PLEASE KEEP FOR FUTURE REFERENCE, READ CAREFULLY.

DO NOT FULLY TIGHTEN SCREWS UNTIL COMPLETELY ASSEMBLED.

**RU-** ВАЖНО: СОХРАНИТЕ ДЛЯ ДАЛЬНЕЙШЕГО ИСПОЛЬЗОВАНИЯ, ВНИМАТЕЛЬНО ПРОЧТИТЕ.

НЕ ЗАТЯГИВАЙТЕ ВИНТЫ ДО ОКОНЧАТЕЛЬНОЙ СБОРКИ.

ROCKING WHEEL ASSEMBLY  
СБОРКА КОЛЕСО-КАЧАЛКА

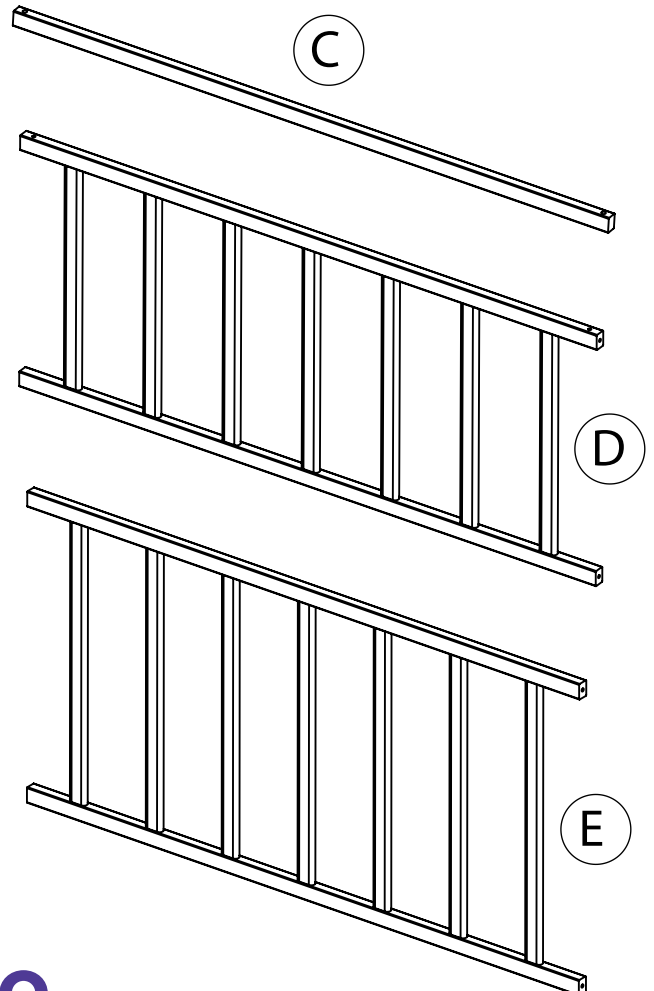
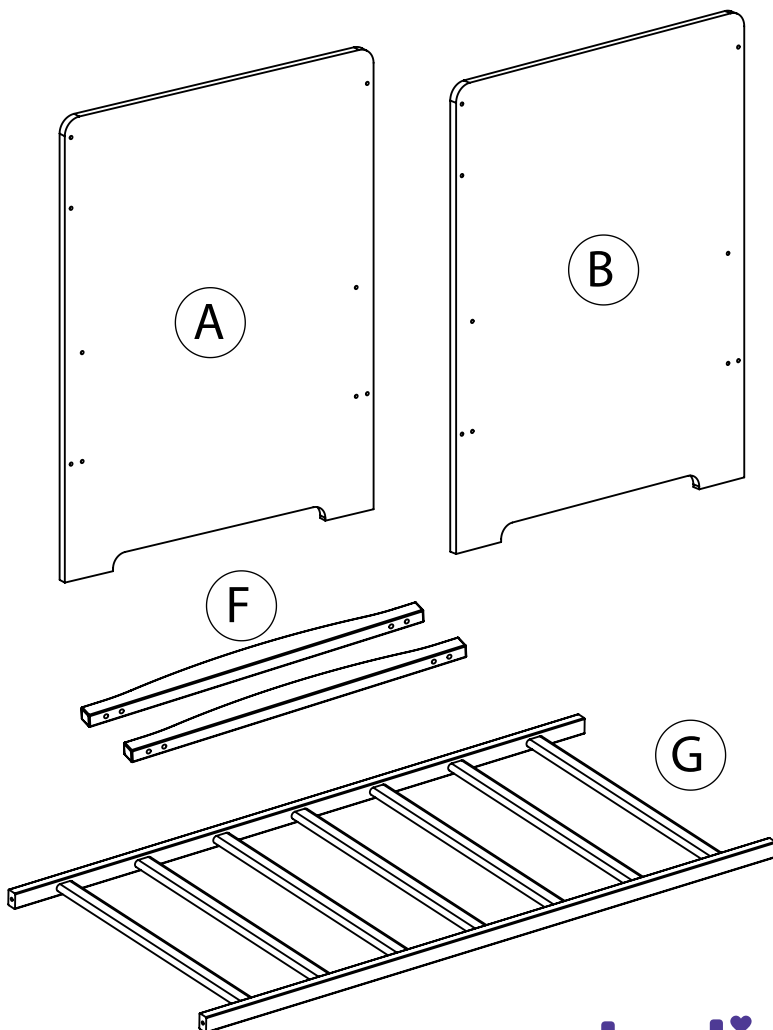
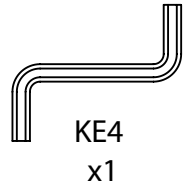
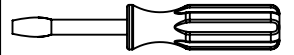
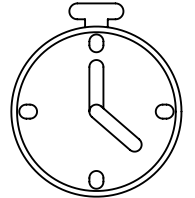
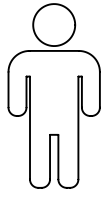
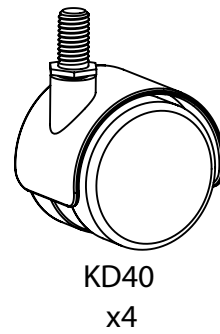
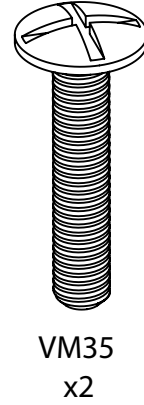
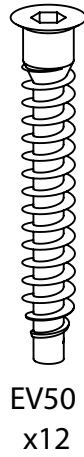
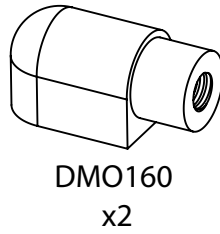
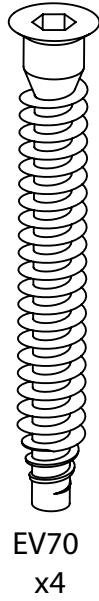
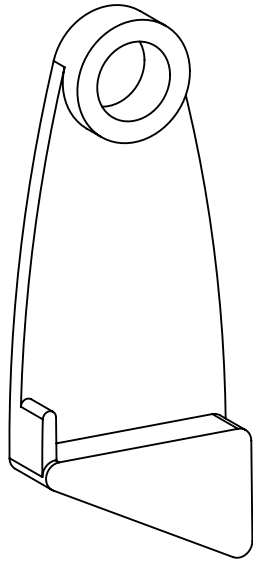
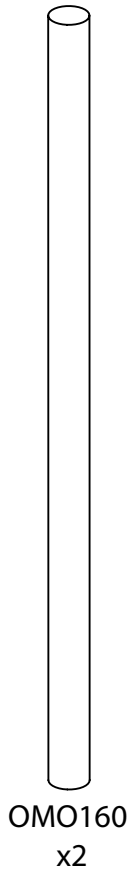

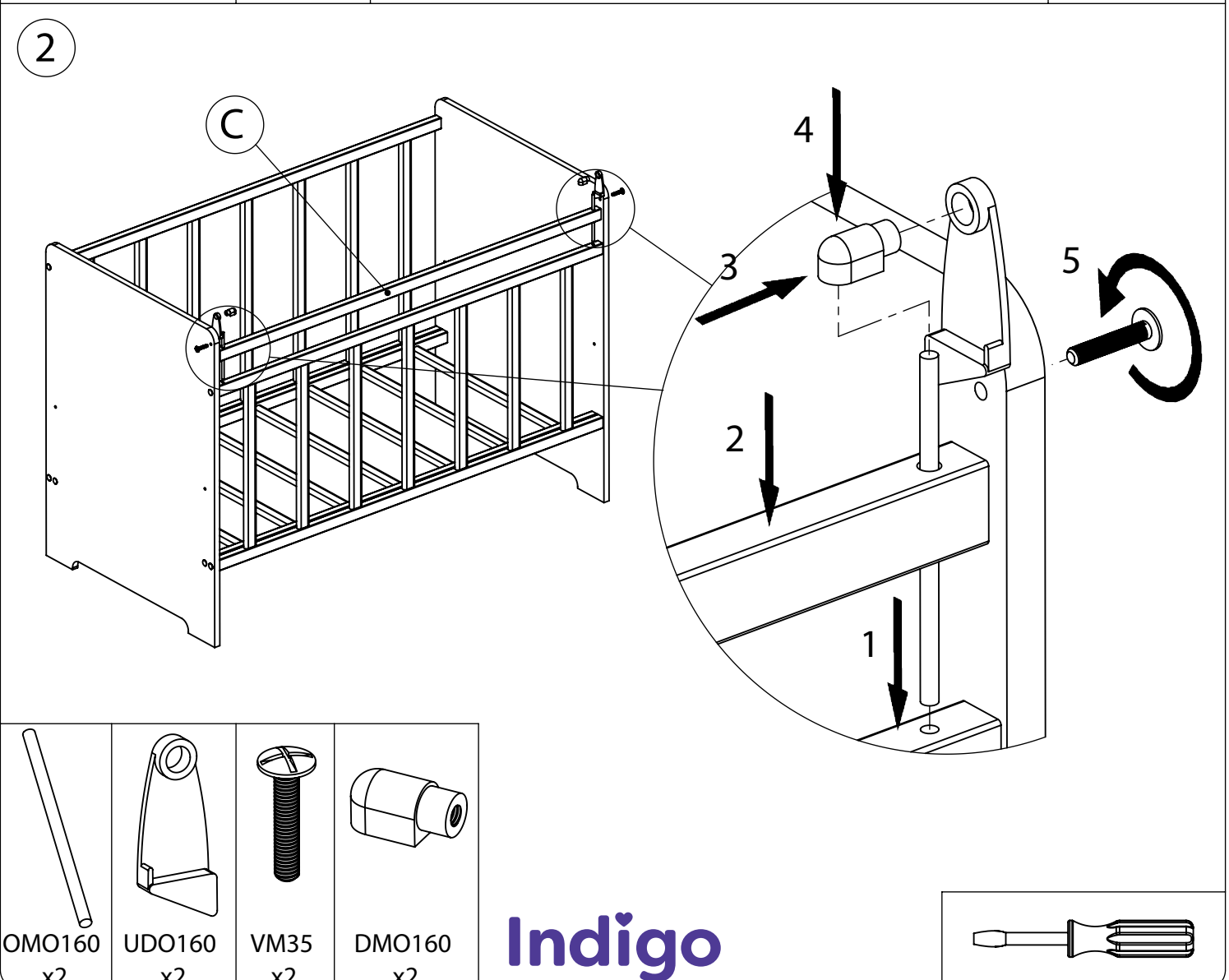
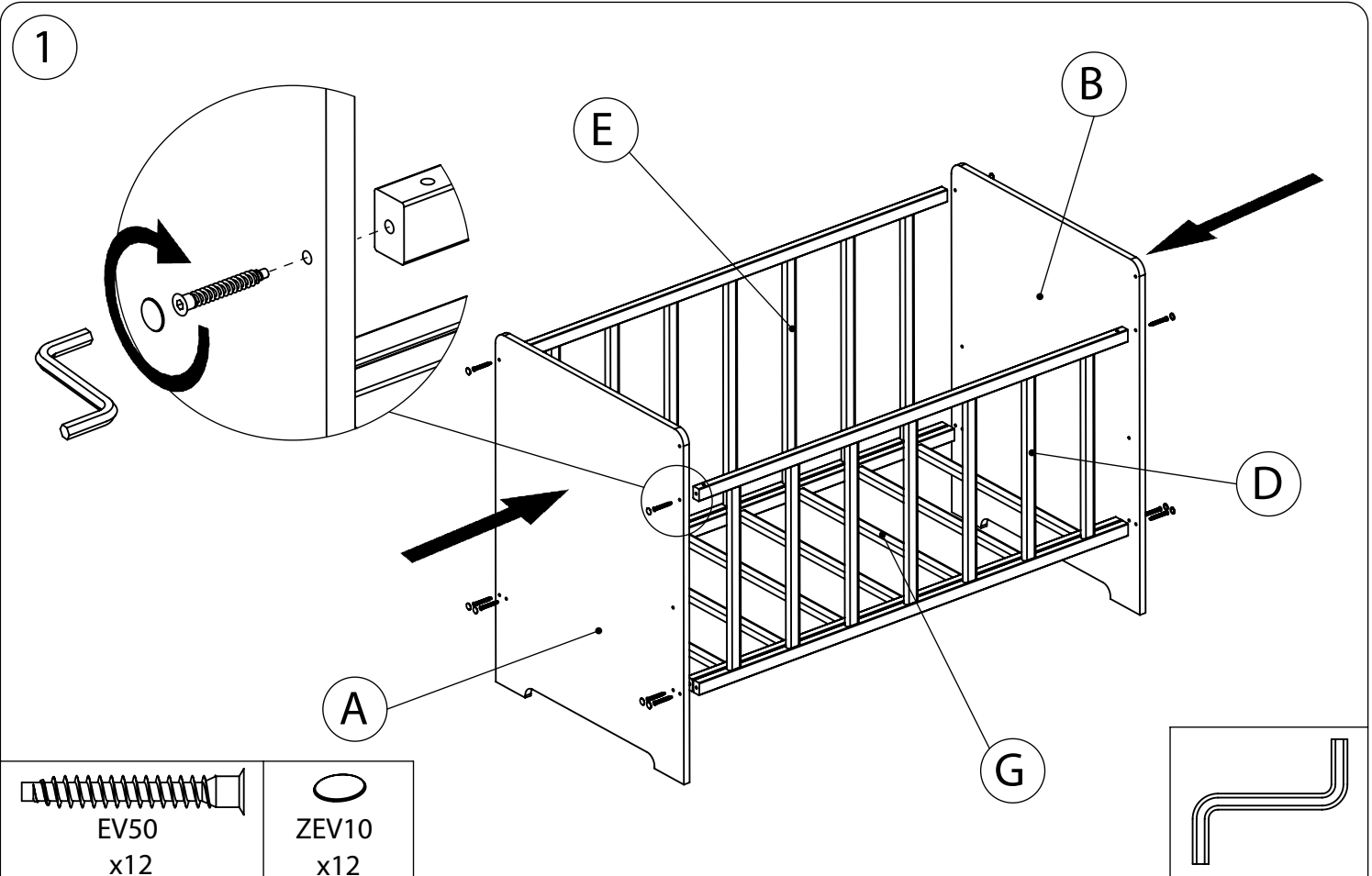

3

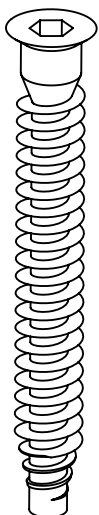
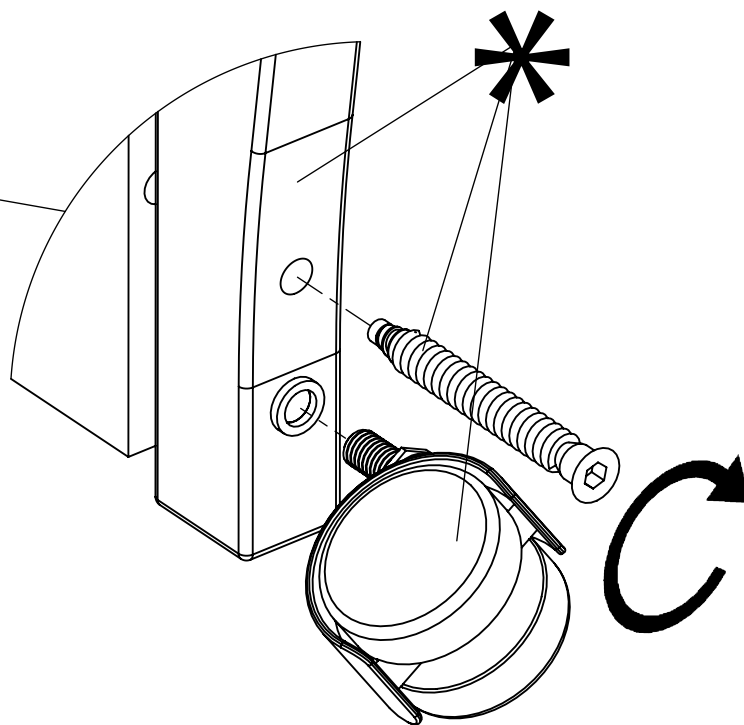
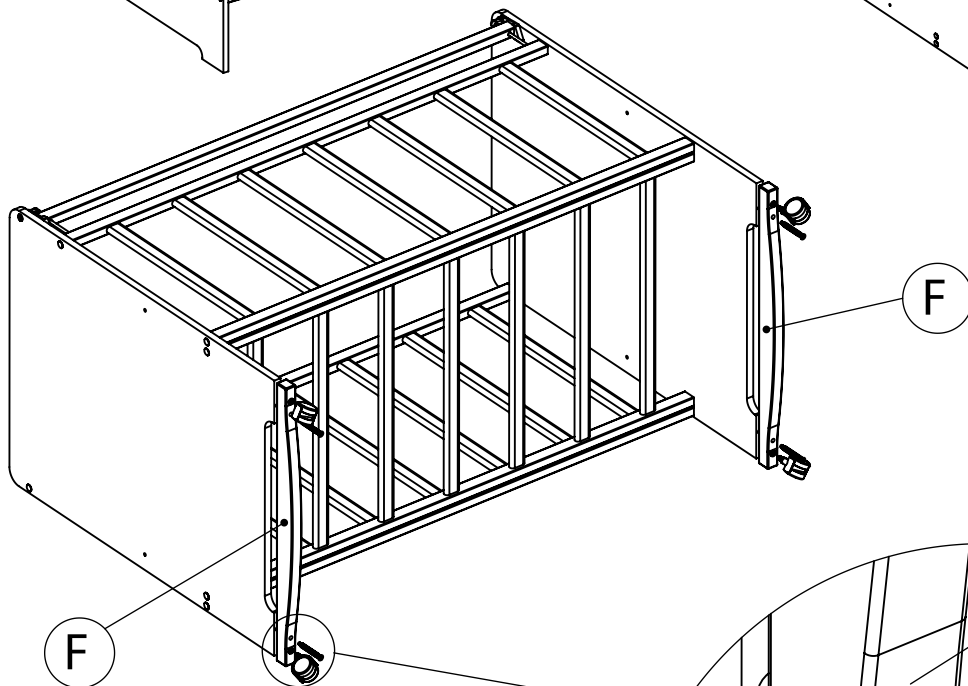
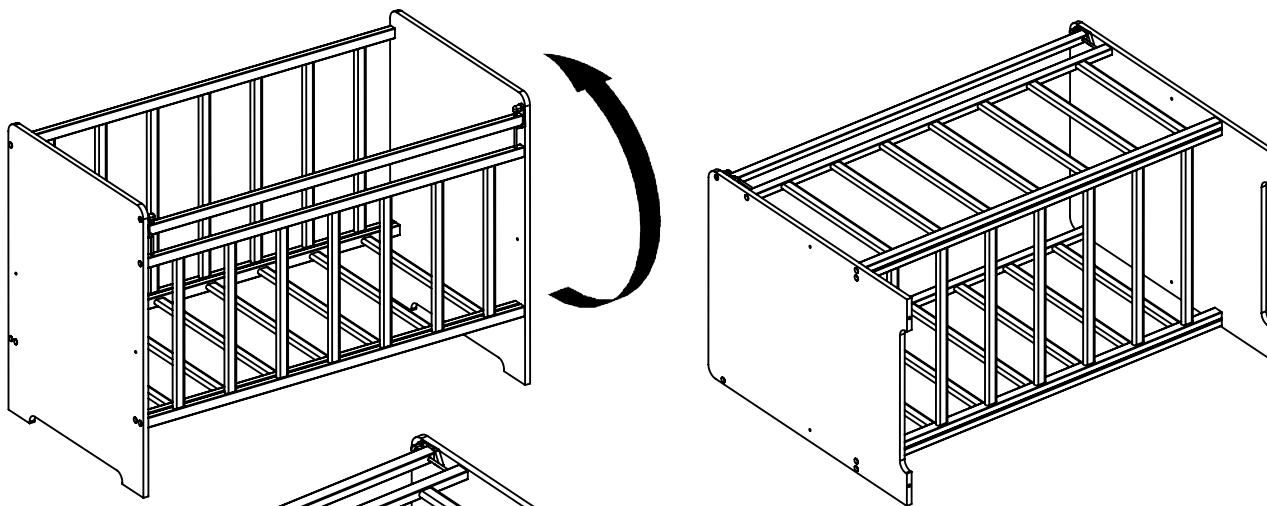
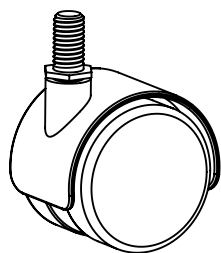
EV70  
x4KD40  
x4

# Indigo

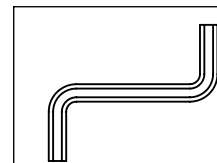

EN- IN THE COMPLETE SET "THE PENDULUM WITH A BOX" ROLLING ELEMENTS,  
WHEELED SUPPORTS AND EUROSCREWS 7x70 NOT USED.

RU- В КОМПЛЕКТАЦИИ КРОВАТИ "МАЯТНИК С ЯЩИКОМ" ЭЛЕМЕНТЫ КАЧАНИЯ,  
КОЛЕСНЫЕ ОПОРЫ И ЕВРОВИНТЫ 7x70 НЕ ИСПОЛЬЗУЮТСЯ.

ASSEMBLY WHEEL-HANGER PENDULUM  
СБОРКА КОЛЕСО-КАЧАЛКА МАЯТНИК

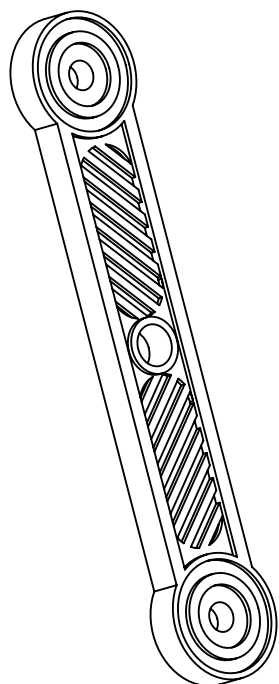

RM148  
x4

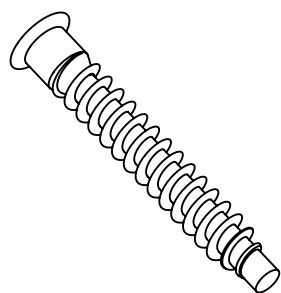

EV50  
x4

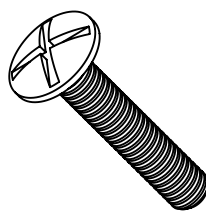

VM35  
x8

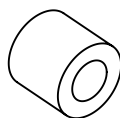

VM6  
x8

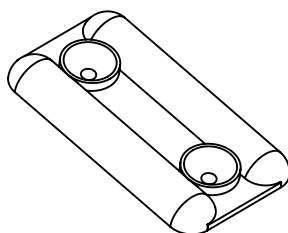

PM35  
x4

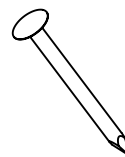

GM15  
x8

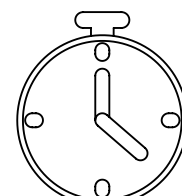
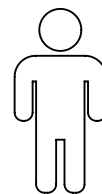

10 min

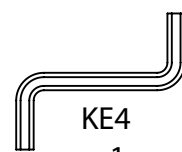

KE4  
x1

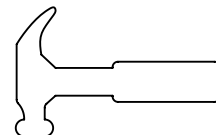

H

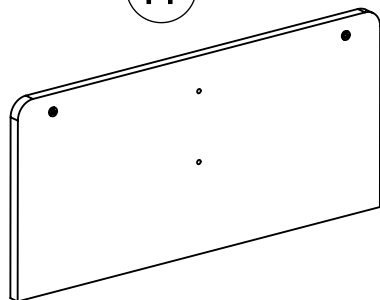

x2

I

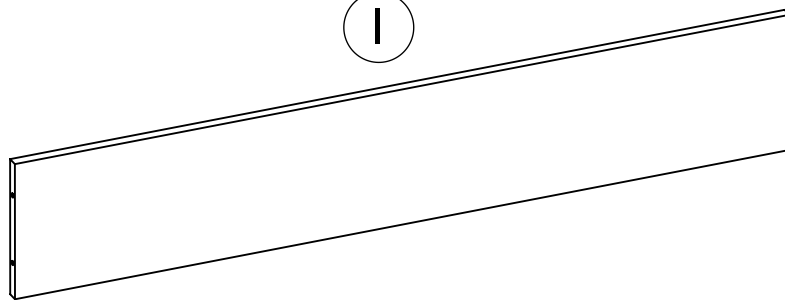

1

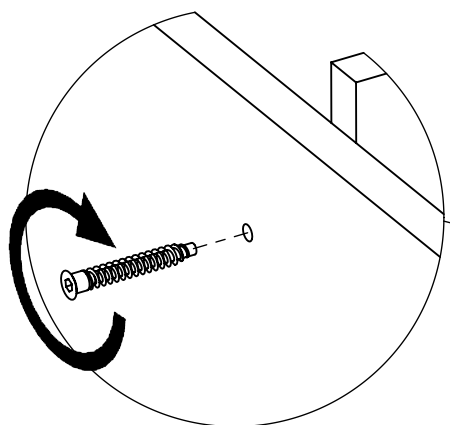

H

H

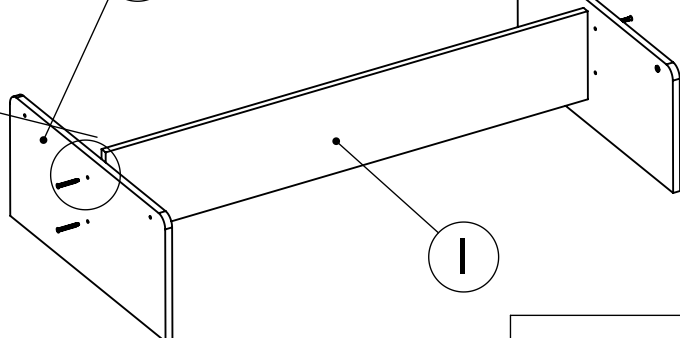

I

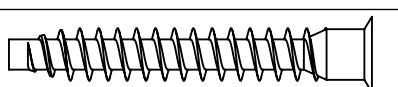

EV50  
x4

Indigo

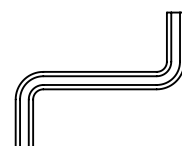

2

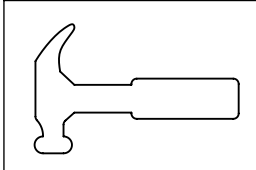
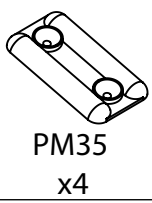
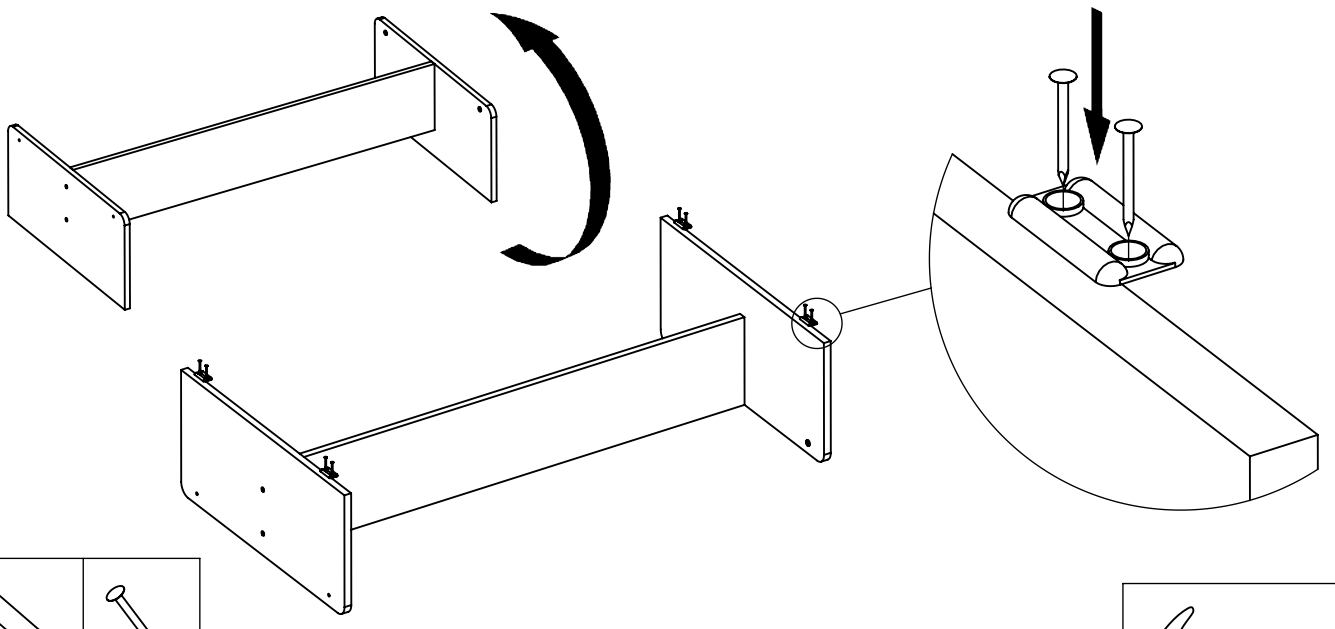

3

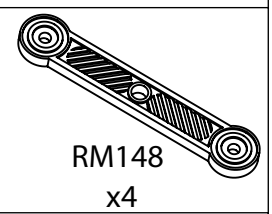
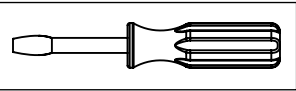
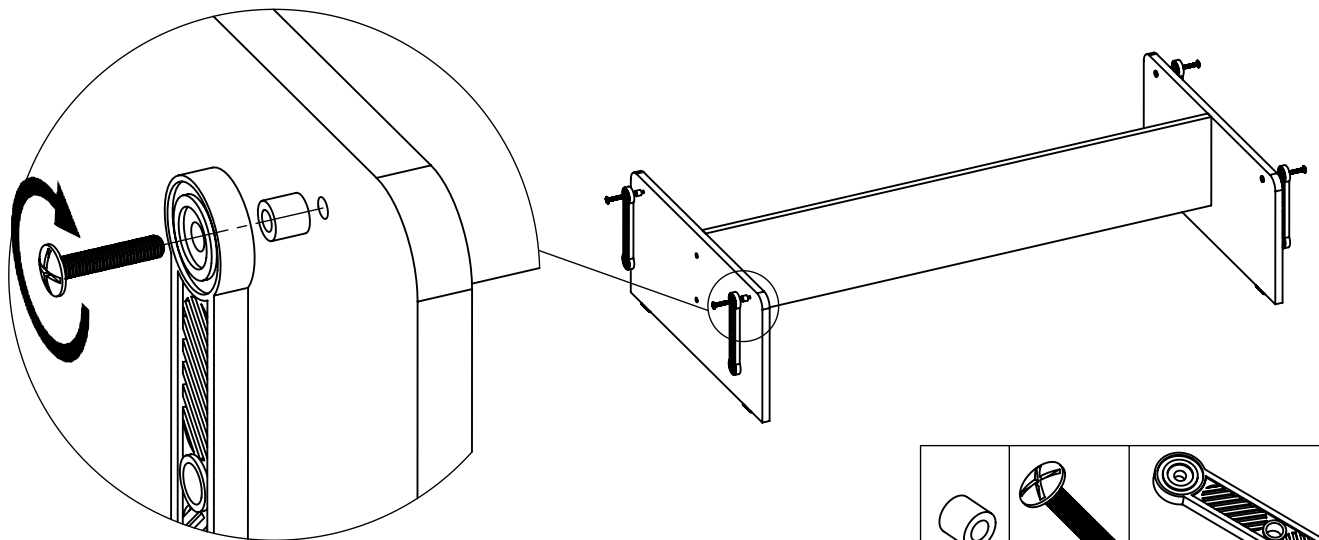

4

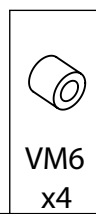
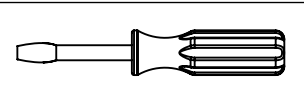
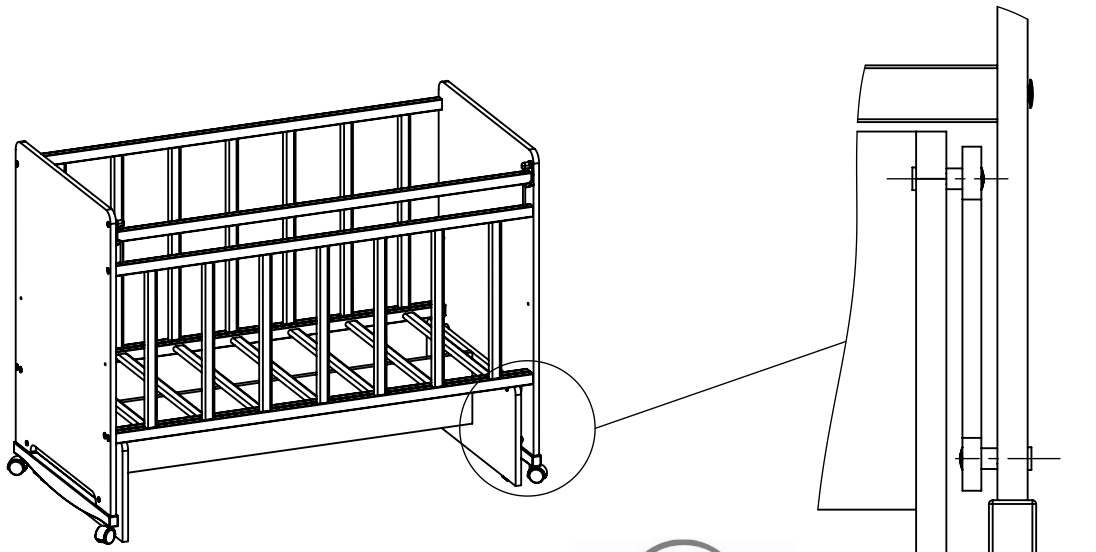

Альма-Няня

ASSEMBLING WHEEL-HANGER WITH BOX  
СБОРКА КОЛЕСО-КАЧАЛКА С ЯЩИКОМ

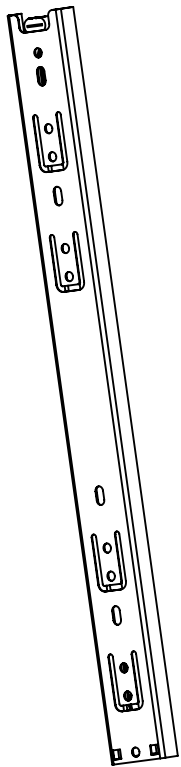

NSH400  
x2

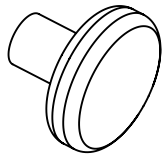

RG30  
x2

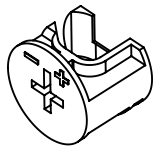

E15  
x2

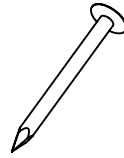

GM15  
x20

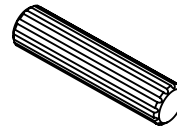

SK30  
x4

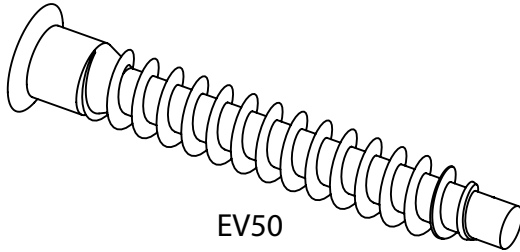

EV50  
x2

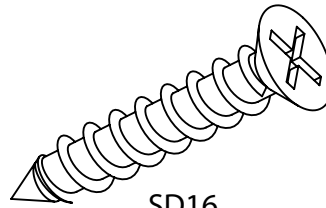

SD16  
x8

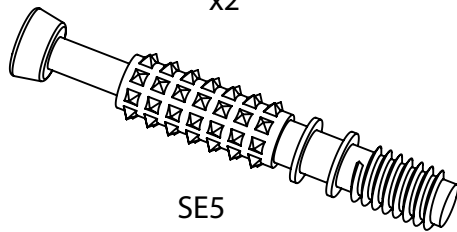

SE5  
x2

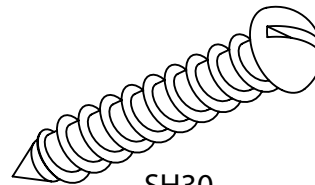

SH30  
x2

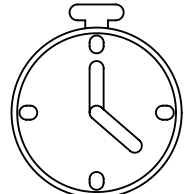
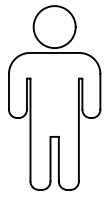

15 min

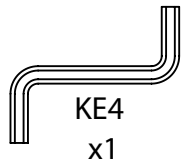
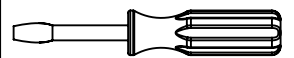

KE4  
x1

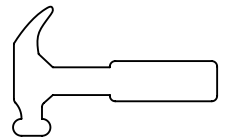

K

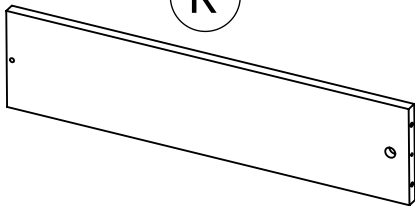

L

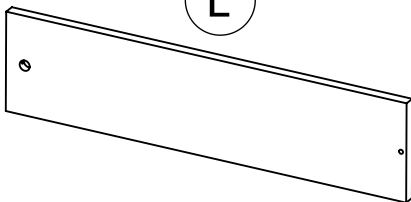

J

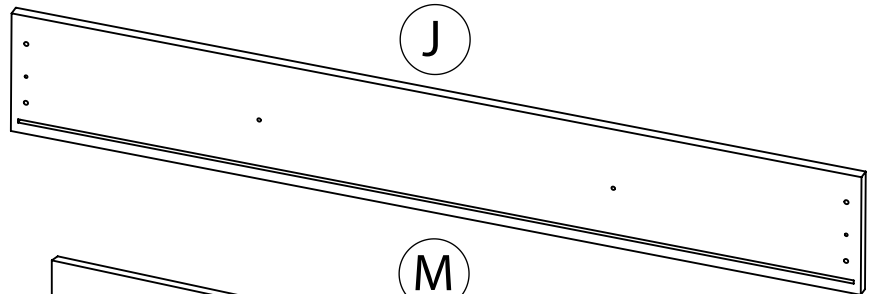

M

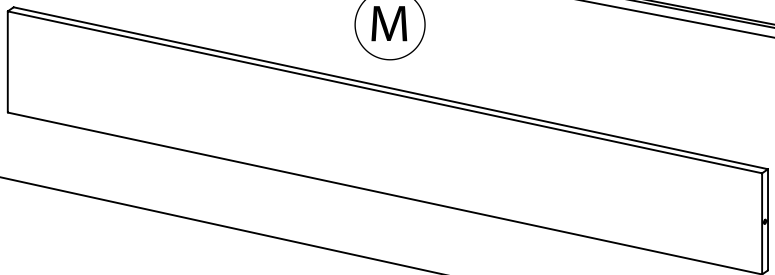



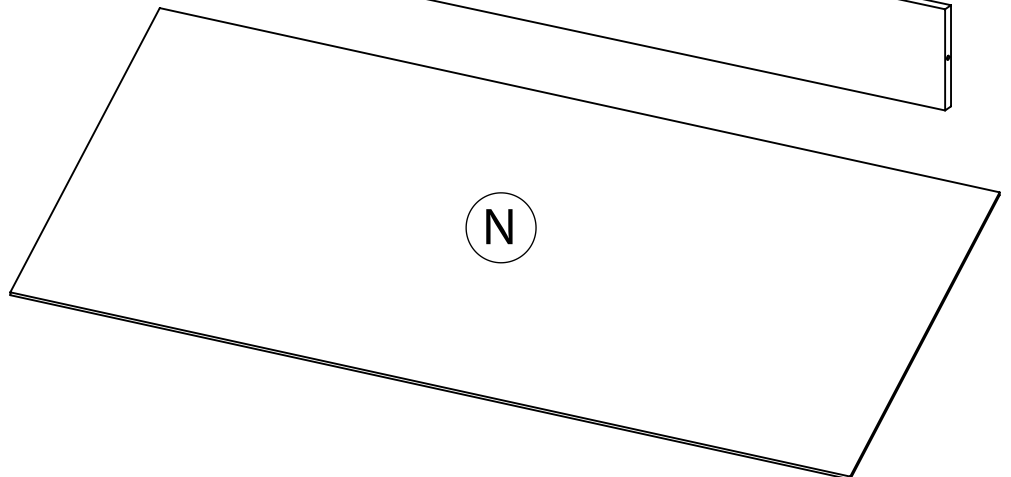



N

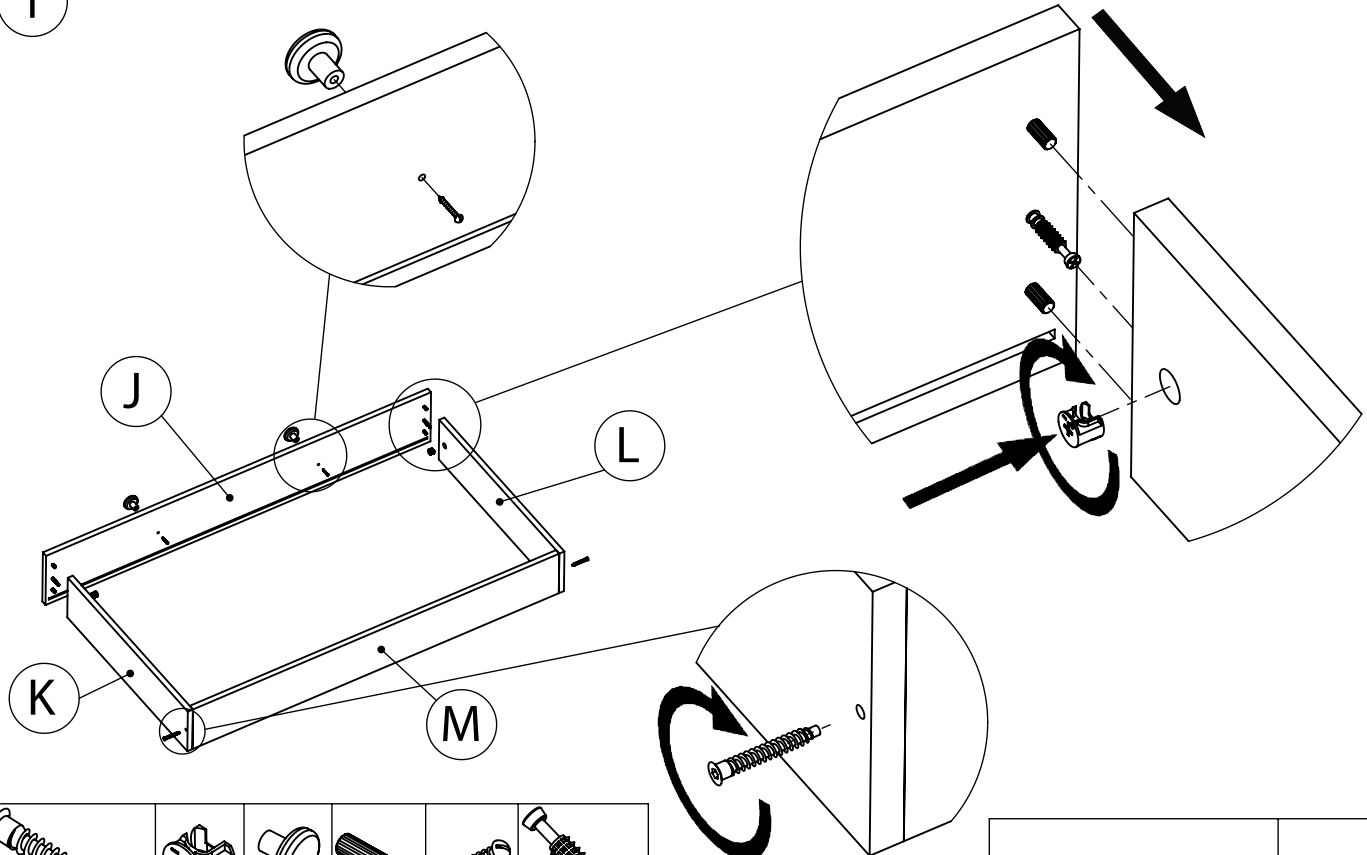

Indigo

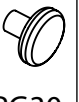
1



					
EV50 x2	E15 x2	RG30 x2	SK30 x4	SH30 x2	SE5 x2

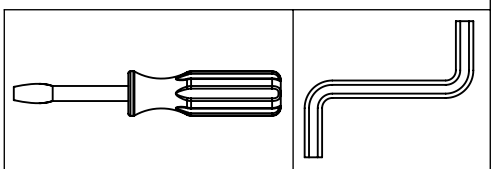

2

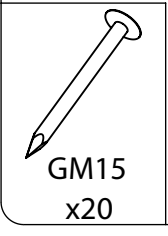
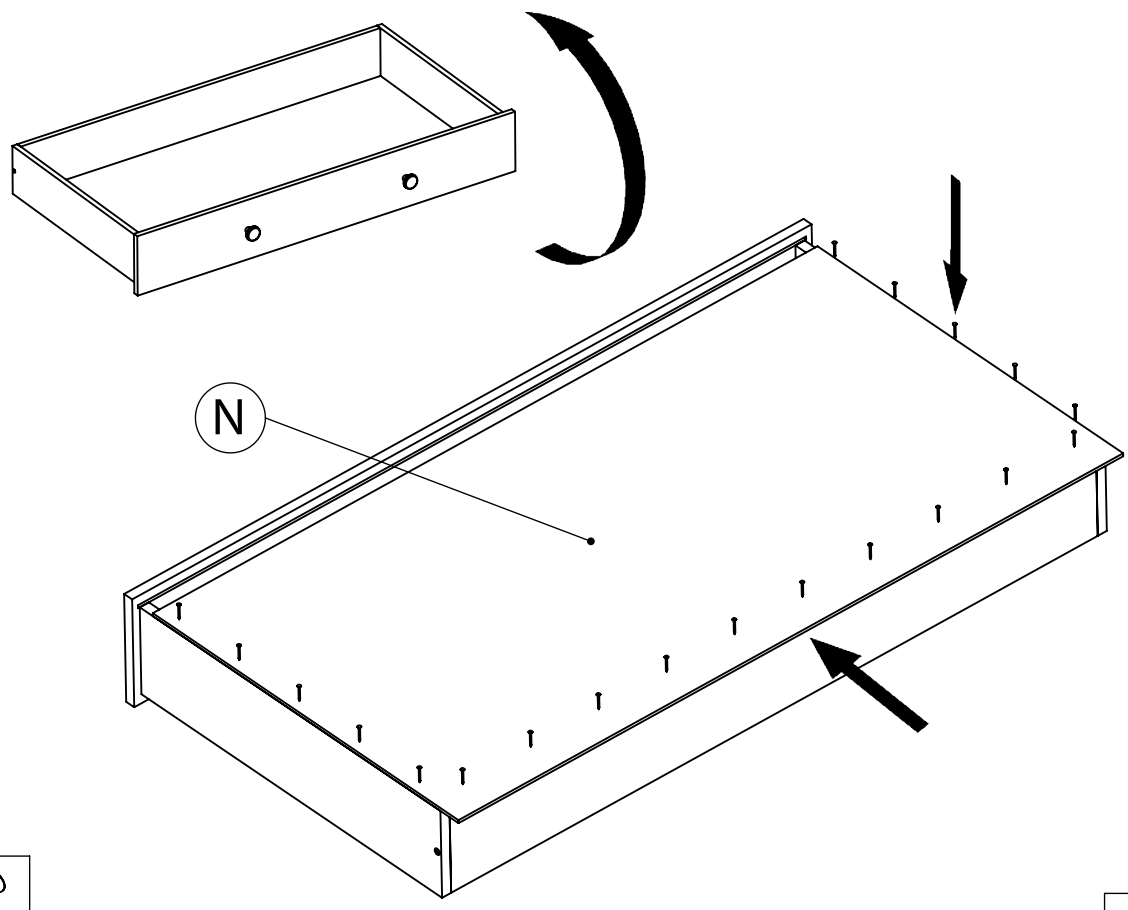

Indigo

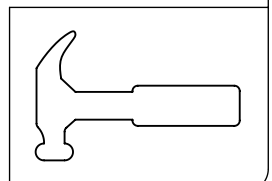



3

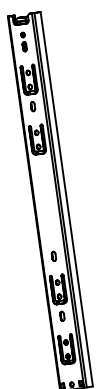
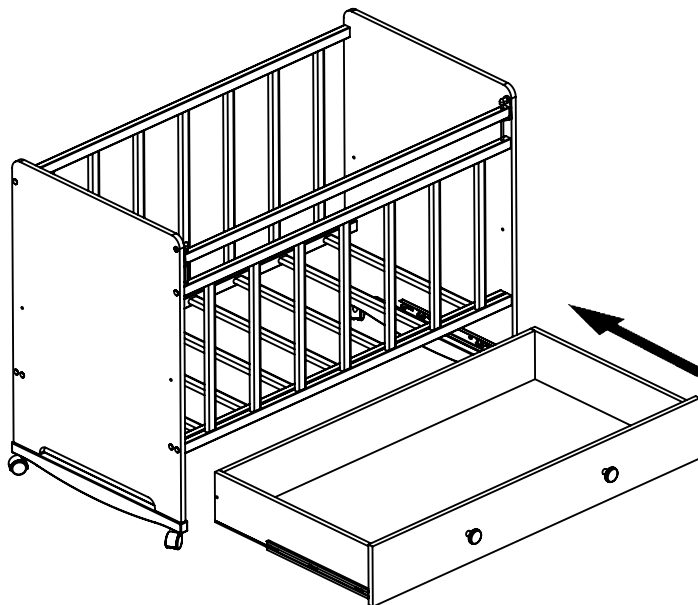
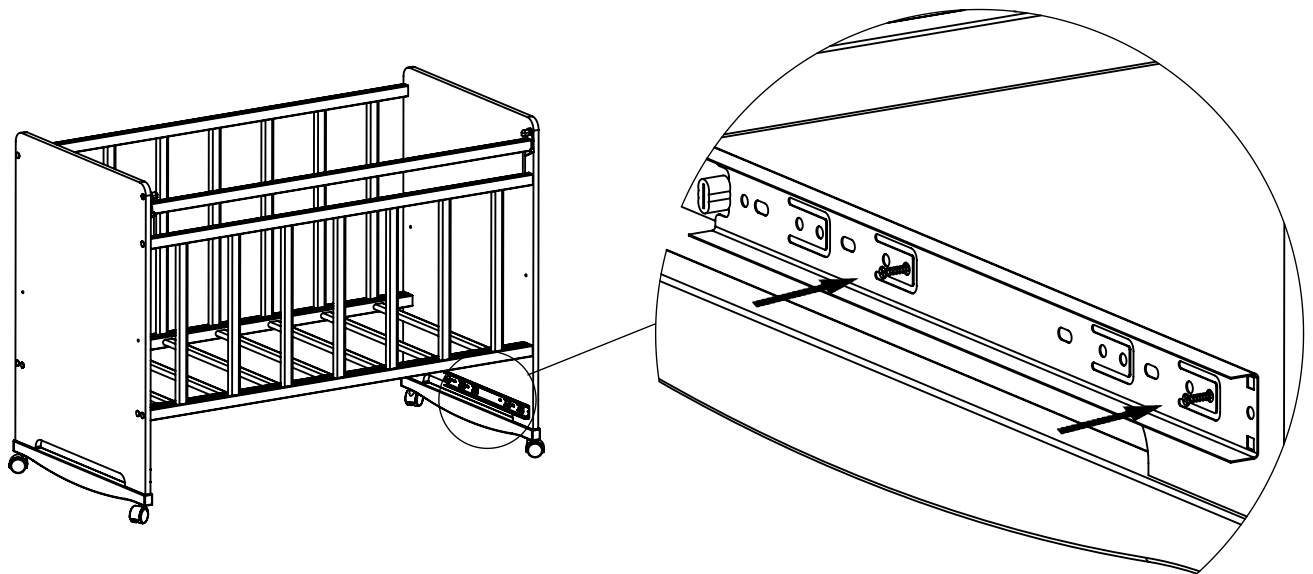
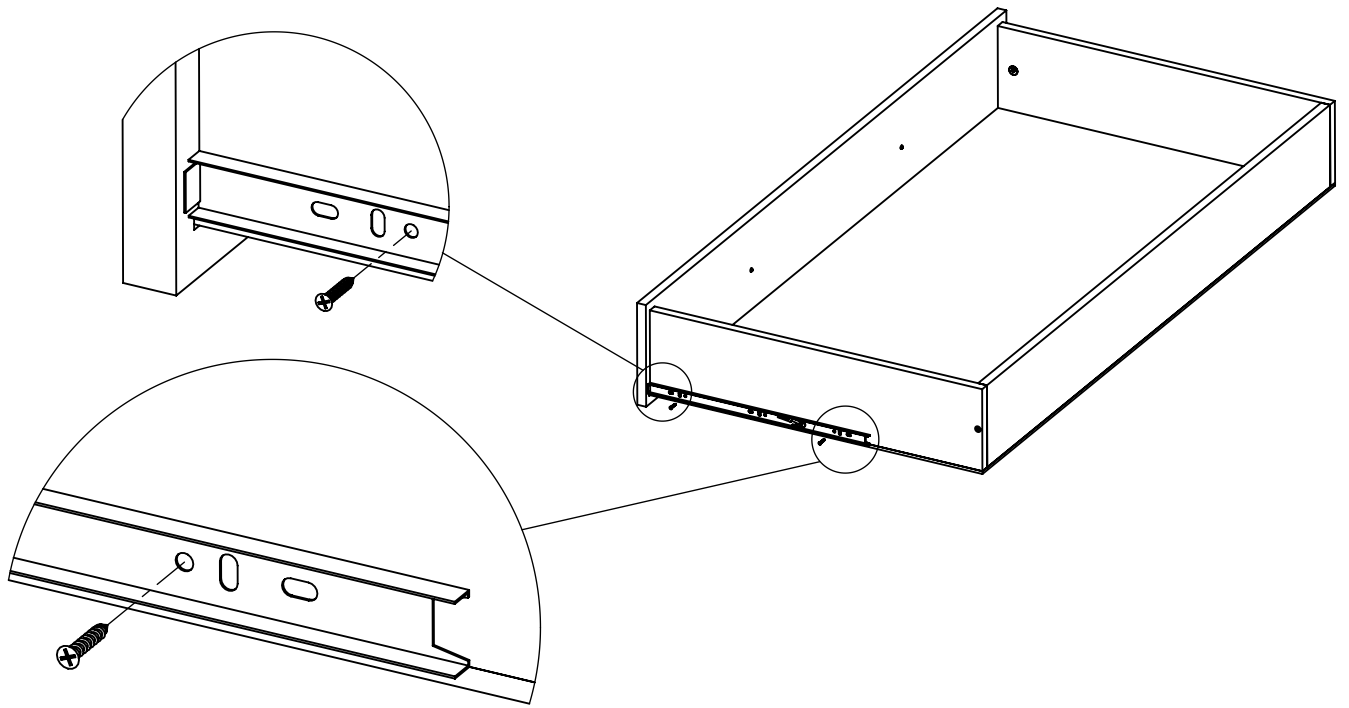

NSH400  
x2

SD16  
x8

Indigo



ASSEMBLING THE PENDULUM WITH A BOX  
СБОРКА МАЯТНИК С ЯЩИКОМ

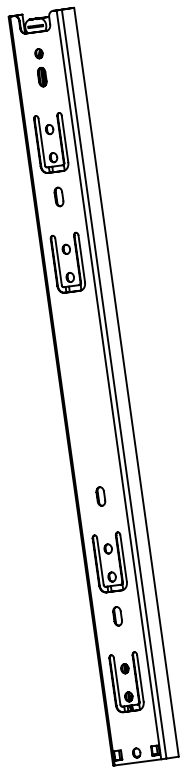

NSH400  
x2

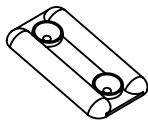

PM35  
x4

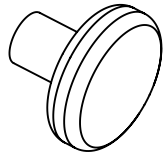

RG30  
x2

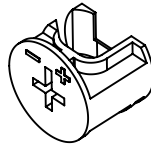

E15  
x2

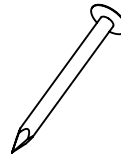

GM15  
x28

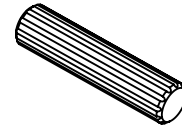

SK30  
x8

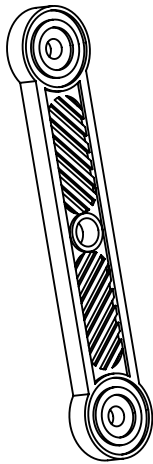

RM148  
x4

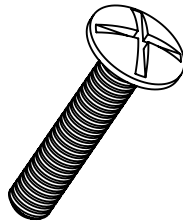

VM35  
x8

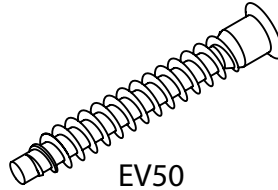

EV50  
x10

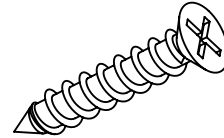

SD16  
x8

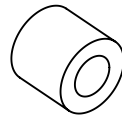

VM6  
x8

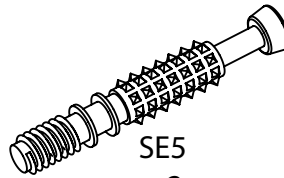

SE5  
x2

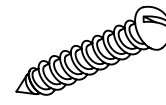

SH30  
x2

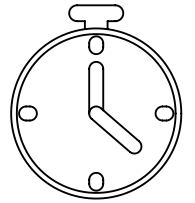
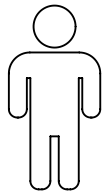

30 min

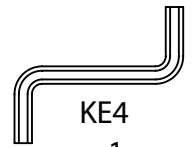
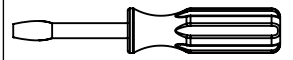

KE4  
x1

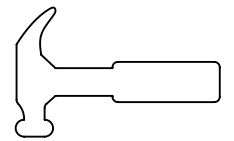

O

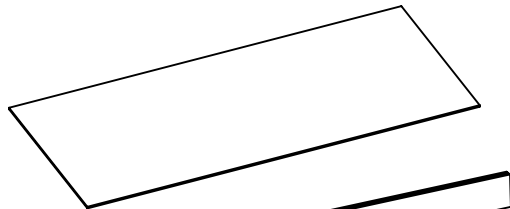

P



Q

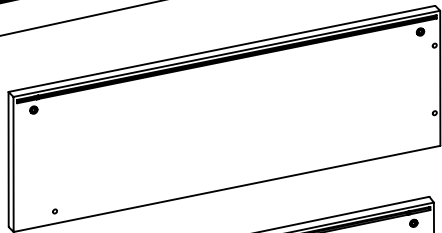

R

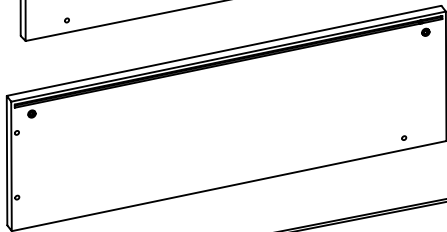

S



T



U

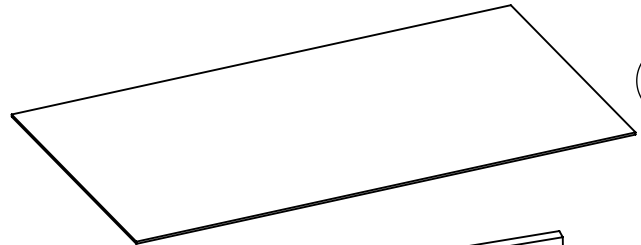

V

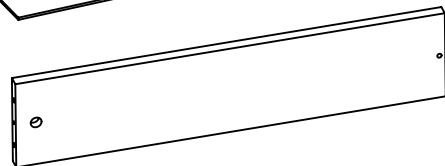

W

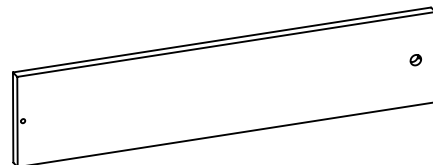

X

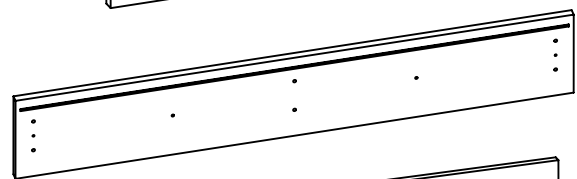

Y

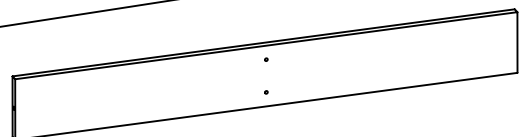

Z

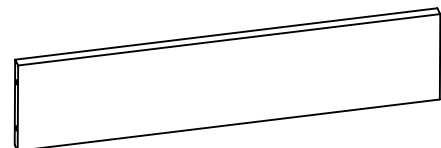

Indigo

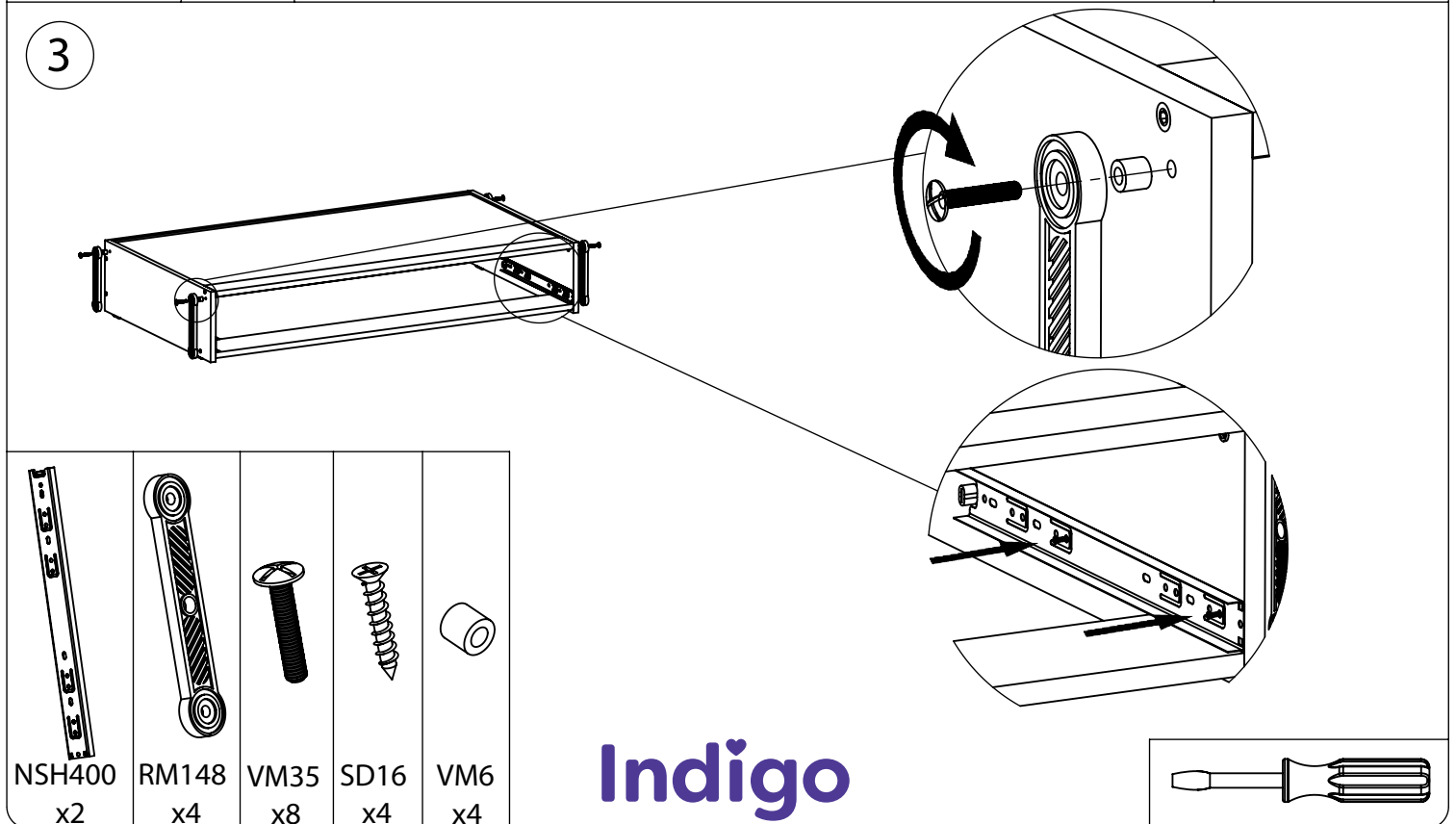
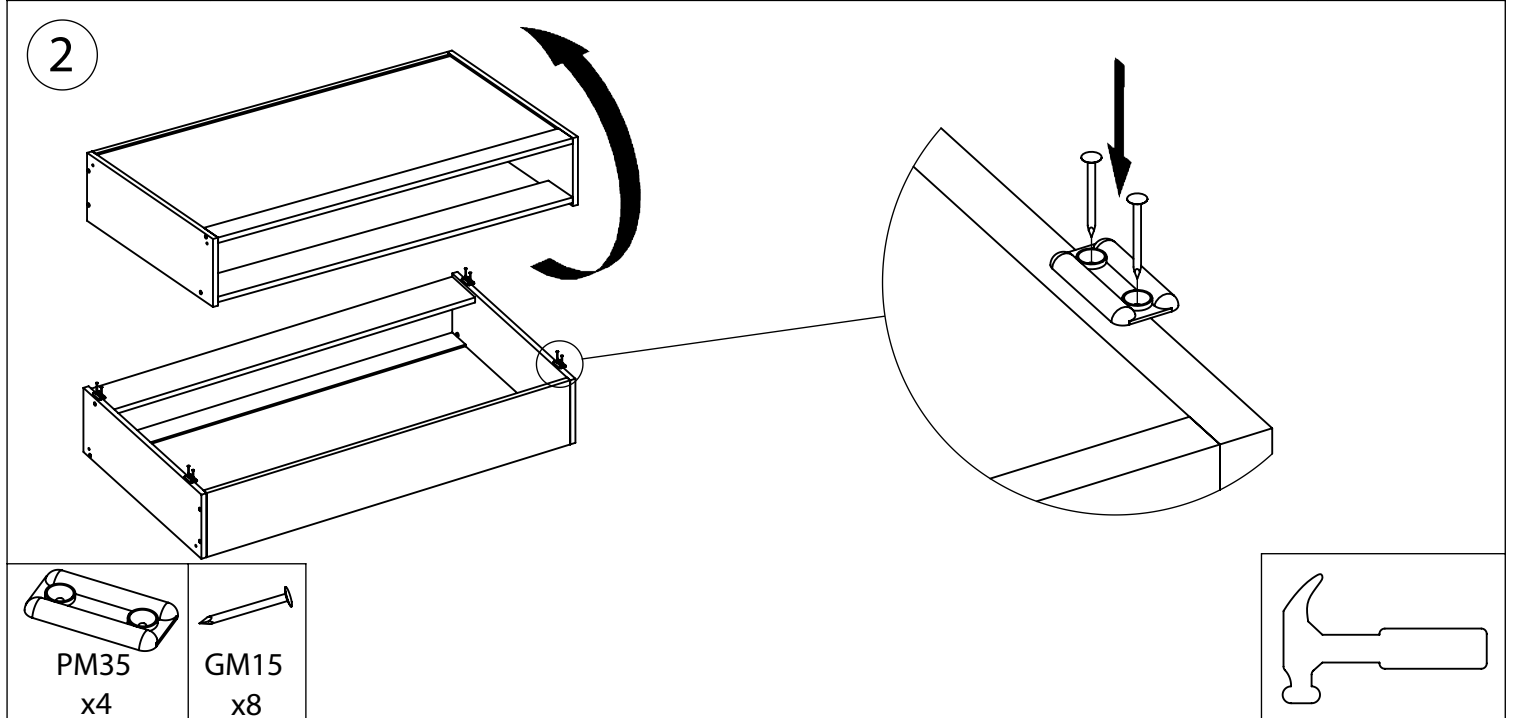
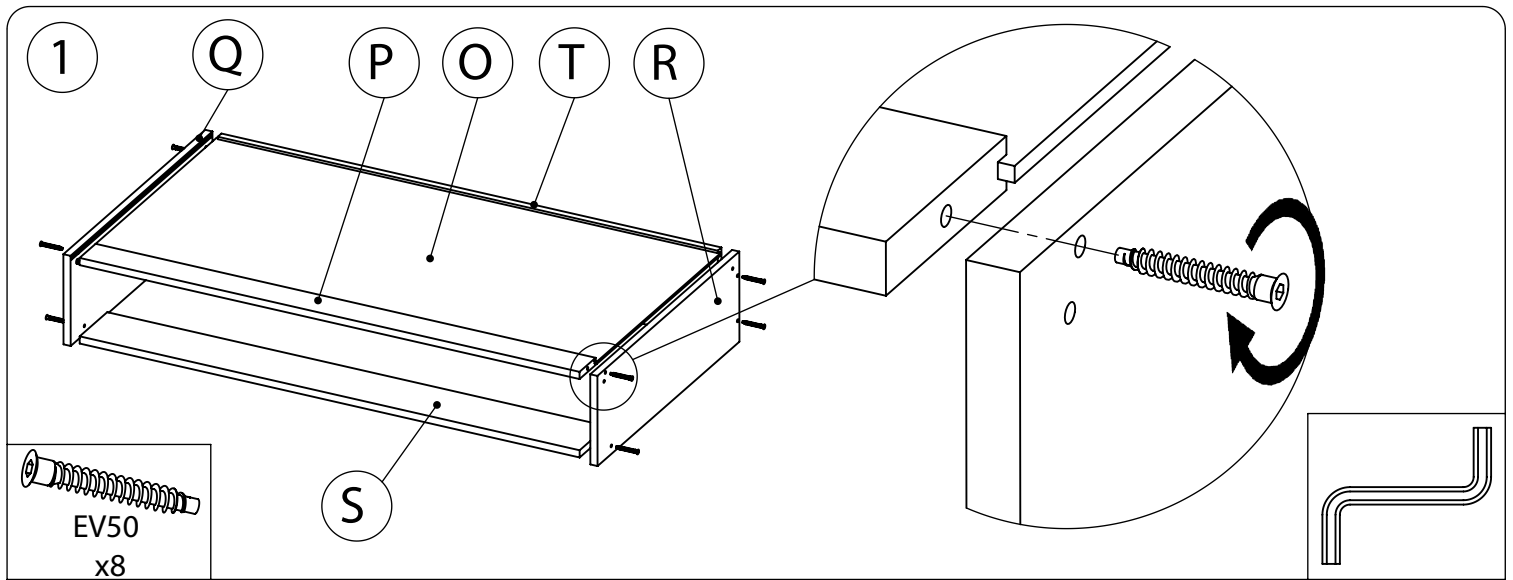

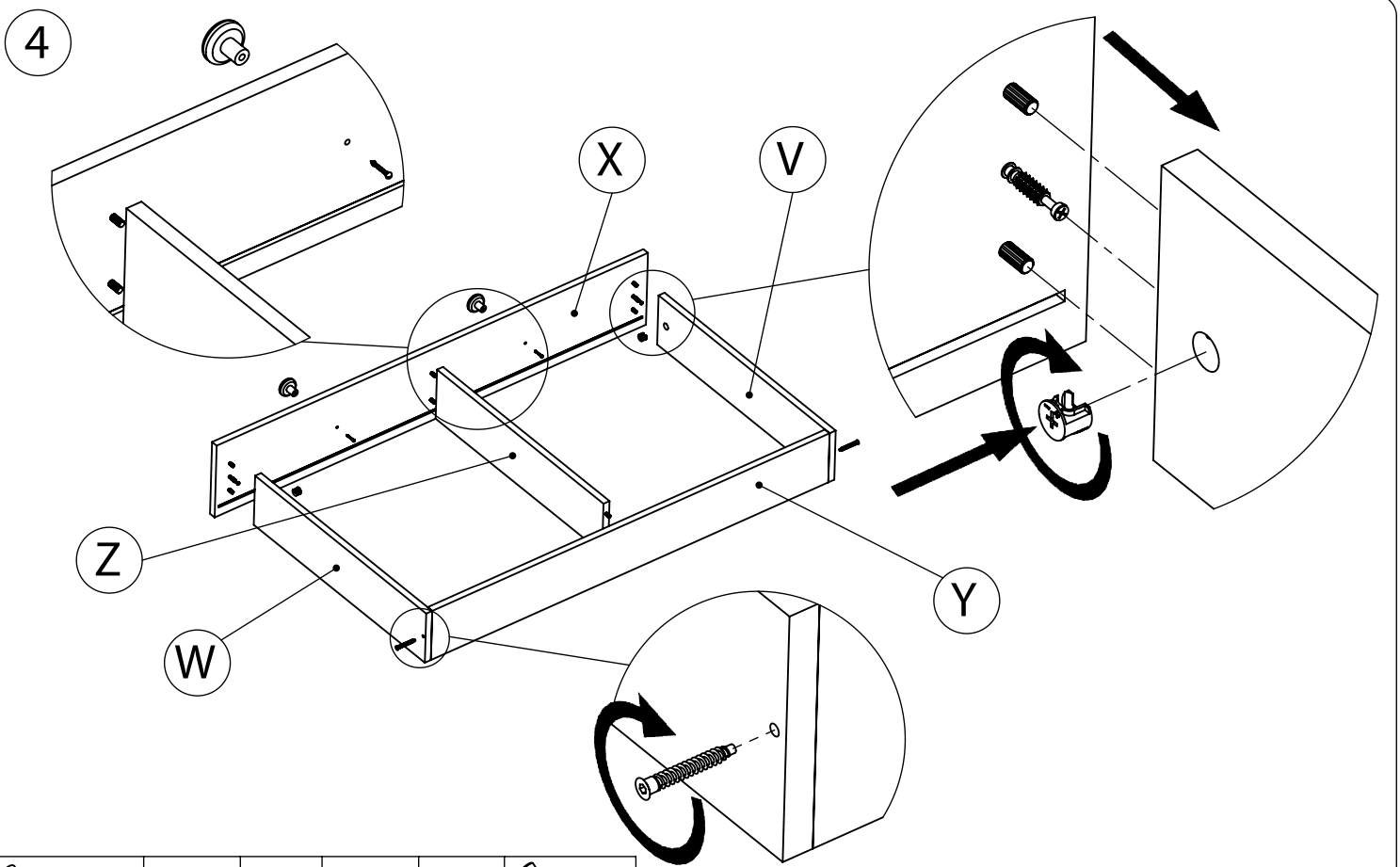

EV50 x2	E15 x2	RG30 x2	SK30 x8	SH30 x2	SE5 x2

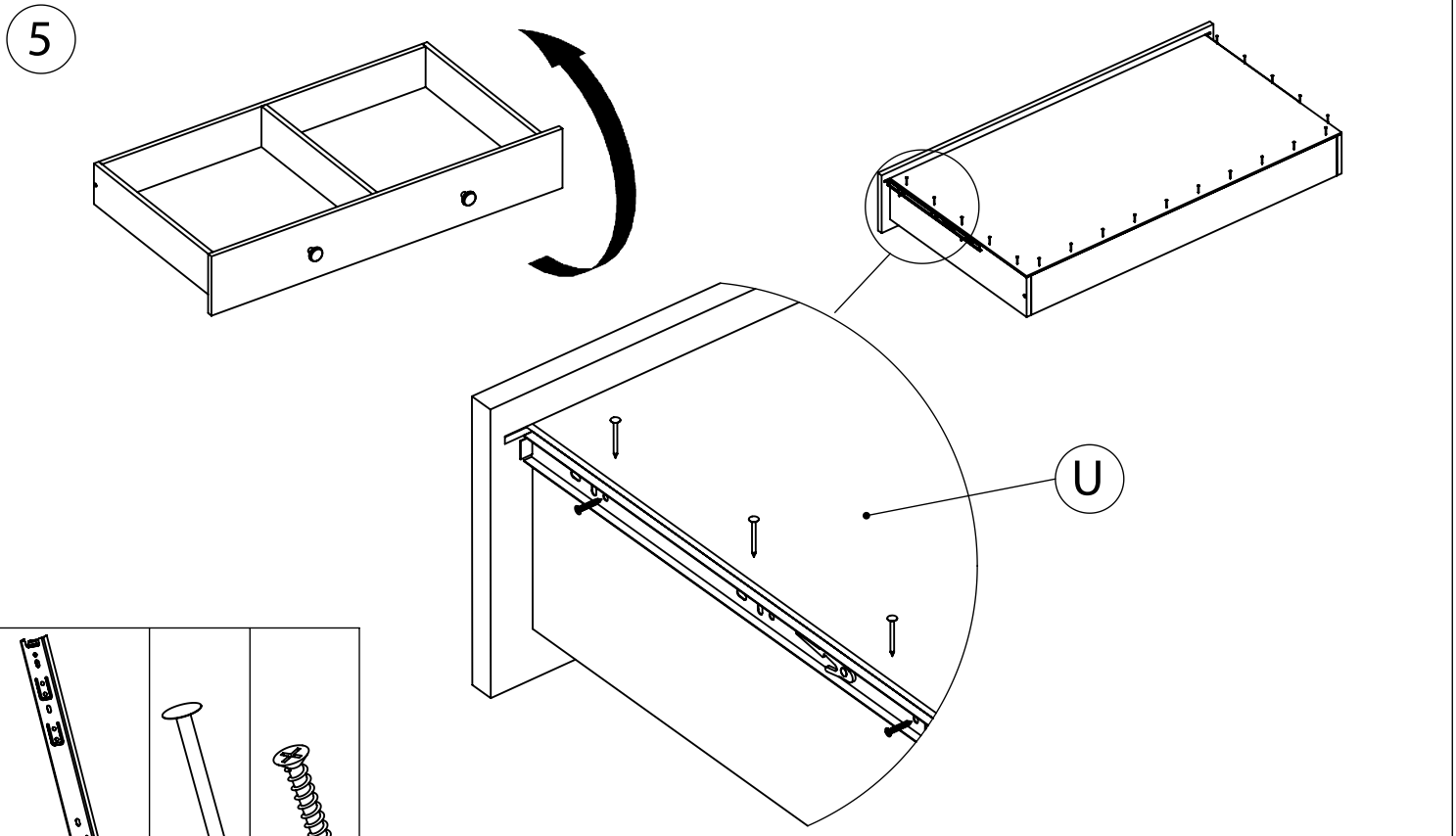
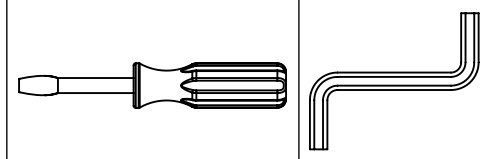

NSH400 x2	GM15 x20	SD16 x4

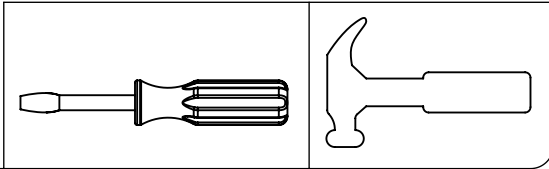

**Indigo**

6

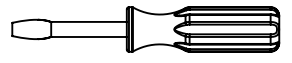
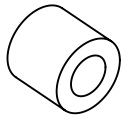
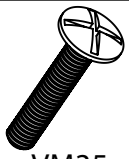
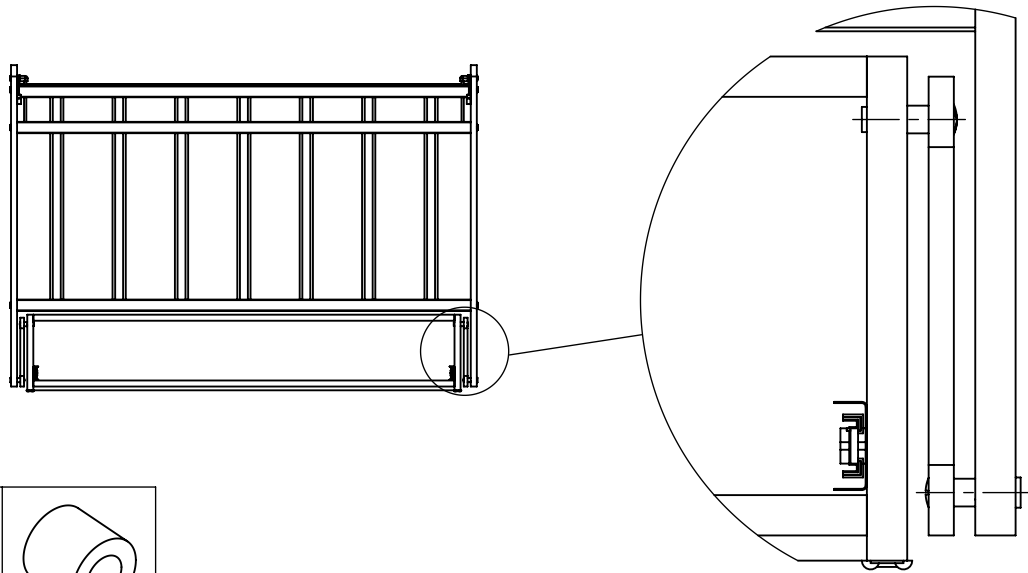

7

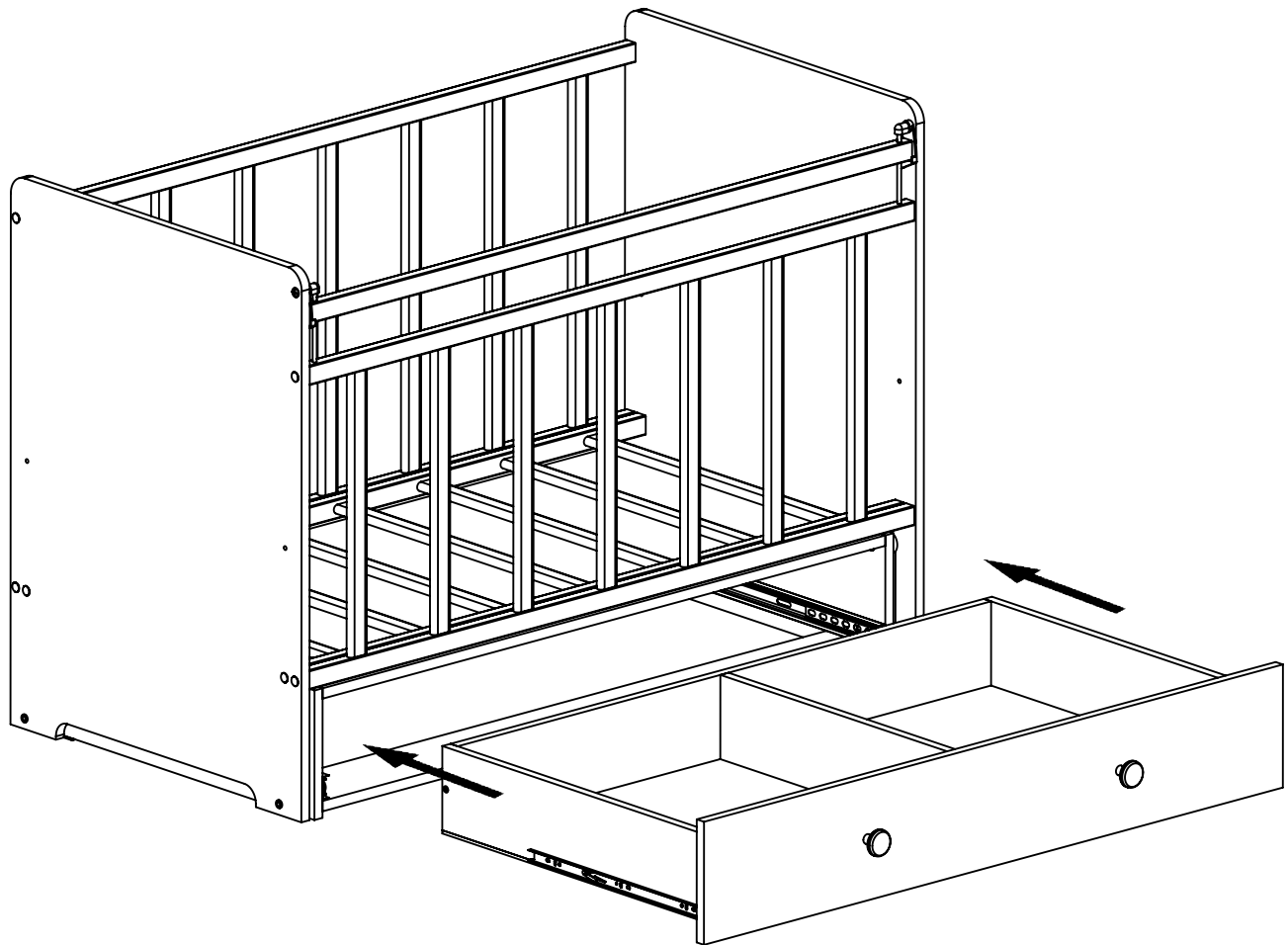

Indigo

## SPECIFICATION / СПЕЦИФИКАЦИЯ

A	Left back / Спинка левая
B	Right back / Спинка правая
C	Lowering bar / Планка опускания
D	Small shield / Щит малый
E	Big shield / Щит большой
F	Rolling support / Опора качения
G	Lounger / Лежанка
H	Pendulum support / Опора маятника
I	Pendulum jumper / Царга маятника
J	Drawer facade / Фасад ящика
K	Right panel drawer / Правая панель ящика
L	Left panel drawer / Левая панель ящика
M	Drawer rear panel / Задняя панель ящика
N	Drawer bottom / Дно ящика
O	Box top / Верх короба
P	Upper plank of the box / Верхняя планка короба
Q	The left panel of the box / Левая панель короба
R	The right panel of the box / Правая панель короба
S	Lower plank of the box / Нижняя планка короба
T	Back panel of the box / Задняя панель короба
U	Drawer bottom / Дно ящика
V	Left panel drawer / Левая панель ящика
W	Right panel drawer / Правая панель ящика
X	Drawer facade / Фасад ящика
Y	Drawer rear panel / Задняя панель ящика
Z	Drawer jumper / Перемычка ящика
PM35	Footboard / Подпятник
VM35	Screw / Винт М6х35
UDO160	Ear / Ухо
KD40	Wheel / Колесо
DMO160	Holder / Держатель
OMO160	Axis / Ось
GM15	Nail / Гвоздь 1х15
RG30	Knob / Ручка
NSH400	Way / Направляющая 400
ZEV10	Stub / Заглушка
SH30	Screw / Шуруп 4х30
SD16	Self-tapping screw / Саморез 3х16
EV50	EuroscREW / Евровинт 7х50
EV70	EuroscREW / Евровинт 7х70
SE5	Eccentric stock / Шток эксцентрика
SK30	Dowel / Шкант 8х30
VM6	Sleeve / Втулка
E15	Eccentric / Эксцентрик
RM148	Pendulum arm / Рычаг маятника
KE4	Hex wrench / Шестигранный ключ 4

## EN

1. If you leave the baby alone in the cot, assure yourself to fix the movable side in the highest position and lock.
2. **WARNING:** Be aware of the risk of open fire and other sources of strong heat, such as electric bar fires, gas, fires in the near of the cot.
3. **WARNING:** Do not use the cot if any part of it is broken, torn or missing and use only spare parts by the manufacturer.
4. Do not leave anything in the cot or place near the cot any product, which could provide a foothold or present a danger of suffocation or strangulation, e.g. strings, blind/curtain cords, etc.
5. **WARNING:** do not use more than one mattress in the cot.
6. Statement that a cot is ready for use only when the locking mechanisms are engaged and check carefully that they are fully engaged before first use.
7. If the height of the cot-base is adjustable, a statement that the lowest position is the safest and that the base should always be used in that position when the baby is old enough to sit up.
8. If you leave the baby alone in the cot, assure yourself to fix the movable side in the highest position and lock.
9. Thickness of the mattress shall be such that the internal height ( surface of the mattress to the upper edge of the cot frame) is at least 500 mm in the lowest position of the cot base and at least 200mm in the highest position of the cot base.
10. The length of the mattress shall be such that the gap between the mattress, the sides and ends does not exceed 30 mm.
11. Cleaning instructions: For cleaning please use a wet and smooth cloth
12. Statement to prevent injury from falls once the child is able to climb out of the cot, the cot shall no longer be used for that child

## RU

1. Если Вы оставляете ребенка одного в кроватке зафиксируйте подвижную боковину в верхнем положении.
2. **Важно:** Помните об опасности открытого огня и других источников сильного тепла, таких как электрические и газовые плиты и т.д. в непосредственной близости от кроватки.
3. **Важно:** Не используйте кроватку, если некоторые из деталей повреждены или отсутствуют, всегда используйте запасные части, предоставленные производителем.
4. **Важно:** Не оставляйте никакие предметы в кроватке и рядом с ней, которые могут служить опорой для ног ребенка или представлять опасность удушья ребенка: например, веревки; шнуры от занавесок, жалюзи и т.д.
5. **Важно:** Не используйте более одного матраса в кроватке.
6. Кроваткой можно пользоваться только после того, как запорные механизмы установлены и тщательно проверена их надежная работа.
7. Если высота ложа кроватки поддается регулировке, самая нижняя позиция является самой безопасной, и эту позицию необходимо использовать когда ребенок достаточно вырос, чтобы самостоятельно сидеть.
8. Если Вы оставляете ребенка одного в кроватке зафиксируйте подвижную боковину в верхнем положении.
9. Толщина матраса должна быть такой, чтобы внутренняя высота (от поверхности матраса до края кроватки) составляла не менее 500 мм в нижнем положении ложа кроватки и не менее 200 мм в верхнем положении ложа кроватки.
10. Размер матраса должна быть такой, чтобы зазор между матрасом и сторонами кроватки не превышал 30 мм.
11. Для чистки используйте влажную и мягкую ткань.
12. Для предотвращения риска выпадения ребенка из кроватки и получения травмы, когда ребенок может вылезти из кроватки самостоятельно, не используйте больше кроватку для этого ребенка.